

# MANDRINI A CAMBIO RAPIDO PER MASCHIATURA E FORATURA SERIE 10000

QUICK CHANGE TAPPING CHUCK FOR DRILLING  
AND TAPPING SERIE 10000  
SCHNELLWECHSELFUTTER FÜR BOHREN UND  
GEWINDESCHNEIDEN SERIE 10000

APPAREILS À TARAUDER À CHANGEMENT RAPIDE  
POUR PERÇAGE ET TARAUDAGE SERIE 10000  
CONO DE ROSCADO DE CAMBIO RÁPIDO  
PARA BROCA Y MACHO SERIE 10000

## Per trapani e macchine tradizionali.

*For drilling and tapping on traditional machines.*

Zum Bohren und Gewindeschneiden auf Konventionellen Bohrmaschinen.

*Pour perceuses et machines traditionnelles.*

Para brocas y machos en máquinas tradicionales.



### Vista del mandrino con bussola cono Morse

*Tapping chuck with Morse taper bush*

Spindel mit Einsätze für Bohren

*Appareil avec douille cone Morse*

Husillo de roscado con casquillo cono Morse

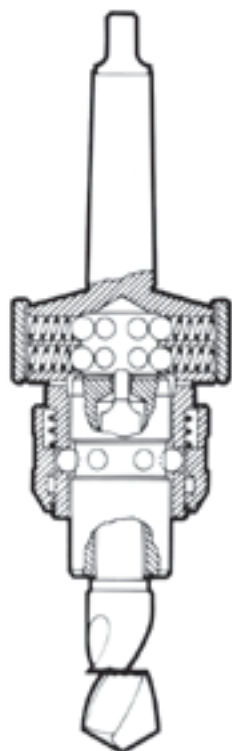

### Vista del mandrino con bussola per maschiatura

*Tapping chuck with bush for tapping*

Spindel mit Einsätze für Gewinde

*Appareil avec douille porte taraud*

Husillo de roscado con casquillo para roscado

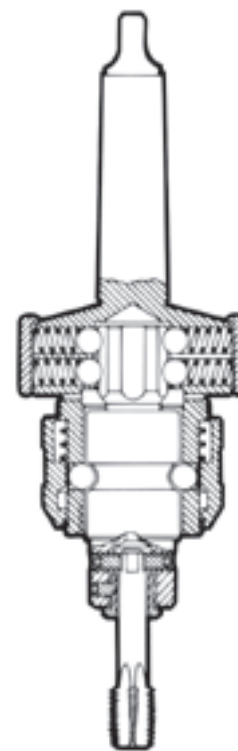

**Mandrino a cambio rapido con dispositivo salvamaschi prearato adatto per maschiatura e foratura.**

Si tratta di un mandrino portautensili ad estrazione rapida con incluso un dispositivo salvamaschi a coppia preconstituita adatto per trapani, alesatrici, torni, ecc.

L'utilità di questo mandrino consiste nella rapidità di passaggio dalle operazioni di foratura a quelle di maschiatura anche su diversi diametri, solo cambiando bussola e senza necessità di registrazioni e controlli di qualsiasi genere.

Per ogni misura di maschio viene fornita una bussola già predisposta e collaudata con coppia appropriata sufficiente per maschiare su qualsiasi materiale.

Tale coppia risulta però nettamente inferiore al momento di rottura del maschio nell'esecuzione di maschiature particolarmente difficili come: maschiature di fori ciechi - diametro di foratura scarso - materiali molto tenaci e ad alta resistenza - usura eccessiva del maschio.

Questa attrezzatura, pur conservando i requisiti di un normale mandrino a cambio rapido (capacità - peso - ingombro) ha il vantaggio di essere nel contempo un eccellente salvamaschi a coppia preconstituita.

L'uso di questo mandrino è particolarmente vantaggioso in caso di fori e filetti di diverse misure da praticarsi in ordine successivo su pezzi pesanti lavorabili su trapani radiali ed alesatrici.

Es.: Stampi - Basamenti per macchine utensili - Strutture in carpenteria, ecc. senza il rischio di incorrere in rottura di maschi su pezzi particolarmente costosi e con notevole risparmio di tempo, semplificando le operazioni di maschiatura.

### Bussola per maschiatura senza compensazione Tipo N

Adatta per uso su macchine di medie dimensioni, aventi avanzamento manuale dotato di scorrevolezza sufficiente per seguire il maschio nell'operazione di maschiatura.

### Bussola per maschiatura con compensazione in sfilamento maggiorata Tipo AS

Da usare su tornio, alesatrice, macchine pesanti in genere per eseguire passi fini anche su materiali teneri. L'uso del mandrino corredato di bussole a sfilamento si rivela molto utile su alesatrici in quanto permette di forare e maschiare con facilità, sfruttando un unico posizionamento senza dover eseguire le centrature e poi passare al radiale per forare e maschiare.

*Quick change tapping chuck with preset saving device for tapping and drilling.*

*This is a quick change chuck provided with a tap protection device for pre-adjustable torques and suitable on drilling machines, lathes etc. The big advantage is the quick change system from drilling to tapping on different diameters by changing only the bush without requiring further adjustments.*

*For each tap size there is a bush for tapping provided with a prearranged torque and tested for tapping any kind of material.*

*Obviously this torque avoids breaking of the tap in difficult tapping operations such as tapping blind holes, very small diameters, very hard and resistant materials or when the tap is excessively worn out.*

*This holder doesn't only meets the requisites of a conventional quick change chuck (capacity/weight/dimensions) but also has the advantage of being an excellent tapping device with pre-adjustable torque.*

*The use of this holder is particularly advantageous when holes and threads of different sizes have to be prepared successively in heavy work pieces that are machined on radial drilling machines.*

*For example: dies, machine tool beds, carpentry work etc.*

*The advantage is that we work without any risk of breaking taps on particularly expensive work pieces and it saves also a lot of time by simplifying tapping operations.*

*Bush for tapping without compensation Type N*

*Adapter for use on machines of middle dimensions, provided with manual feed control.*

*Bush for tapping with axial stroke Type AS*

*For use on lathes, drilling machines and heavy machines in general to make fine pitches also in soft materials.*

*The use of the tapping chuck is particularly advantageous when working with the quick change system on drilling machines that allows to drill and tap in the same position without centring again.*

Schnellwechsel-Gewindebohrspindel mit voreingestellter Spindelsicherung zum Gewindebohren und Bohren

Eine schnellwechselbare Werkzeugspindel mit eingestelltem Drehmoment ist für Bohrmaschinen, Drehbanken, usw. geeignet. Dieser Drehmoment ist für das Gewindeschneiden geeignet, aber der Vorteil ist, dass er niedriger als der Bruchpunkt ist.

Diese Spindel hat auch den Vorteil eines schnellen Übergang von Bohrarbeiten auf Gewindeschneidarbeiten, auch mit unterschiedlichen Durchmessern, lediglich durch Auswechseln der Einsätze, ohne dass irgendwelche Einstellungen oder Kontrollen erforderlich sind.

Für jede Werkzeug-Größe wird ein entsprechender Einsatz geliefert, dessen Bruch-Sicherung auf ein bestimmtes Drehmoment eingestellt ist, damit die Bearbeitung von Werkstoffen aller Art möglich ist.

Dank dieser Werkzeugspindel ist es möglich Löcher und Gewinde verschiedener Größen hintereinander, auch auf schwere und sehr große Teile auf Radialbohr- und Bohrmaschinen herzustellen.

Einsätze zum Gewindebohren ohne Längenausgleich, Typ N

Geeignet für Maschinen mittlerer Größen, welche mit manuellem Vorschub ausgestattet sind, um den Gewindebohrer beim Schneidegang zu folgen.

Einsätze zum Gewindebohren mit Längenausgleich in Zugrichtung, Typ AS

Zum Gebrauch auf Drehbanken, Bohrmaschinen und sonstigen schweren Maschinen geeignet für die Herstellung von Feingängigen Gewinden auf jedem Werkstoff.

Die Anwendung der Spindel mit auswechselbarer Einsätze hat sich als vorteilhaft für Bohrmaschinen erwiesen, da sie den Bohr- oder Gewinde-Schneidvorgang erleichtert, indem nur eine einzige Stellung benutzt wird, ohne eine neue Zentrierung vornehmen zu müssen. Deswegen muss man für die Ausführung nicht auf anderen radialen Bohr- oder Gewindeschneidarbeiten übergehen.

*Appareil à tarauder à changement rapide avec dispositif de sauvegarde du taraud adapté au taraudage et au perçage.*

*Il s'agit d'un mandrin porte-outils à changement rapide possédant un dispositif de sauvegarde du taraud avec un couple pré réglé adapté aux perceuses, aléseuses, tours, etc.*

*L'avantage de ce mandrin consiste à passer rapidement des opérations de perçage à celles de taraudage, même sur des diamètres différents; il suffit de changer seulement la douille sans avoir besoin de modifier les autres réglages.*

*Il est prévu, pour chaque dimension de taraud, une douille déjà pré réglée et vérifiée avec un couple approprié suffisant pour tarauder pratiquement tous les matériaux. Ce dispositif protège complètement le taraud et évite la rupture, même dans les cas difficiles tels que: le taraudage des trous borgnes, diamètre de perçage insuffisant, grande ténacité et haute résistance des matériaux, usure rapide ou excessive du taraud.*

*Cet appareil, tout en gardant les qualités d'un mandrin normal à changement rapide (capacité – poids – encombrement), a l'avantage d'être à la fois une excellente taraudeuse à couple pré réglé. L'usage de ce mandrin est particulièrement intéressant lorsque l'on souhaite réaliser des perçages et taraudages, de différents diamètres, successivement sur des pièces lourdes et encombrantes, sur des perceuses radiales et aléseuses sans avoir besoin de démonter la pièce.*

*Par exemple: moules – embases pour machines-outils - structures de charpente, etc. sans risque de casser des tarauds sur des pièces particulièrement coûteuses et avec un remarquable gain de temps par la simplification des opérations de perçage et de taraudage.*

*Douille porte-taraud Type N*

*Conseillé pour l'usage sur machines de moyenne dimension, avec entraînement manuel particulièrement bien adapté pour suivre le taraud dans l'opération de taraudage.*

*Douille porte-taraud avec course en extension Type AS*

*À utiliser sur tours, aléseuses, machines lourdes en général pour exécuter des pas fins mêmes sur matériaux tendres.*

*L'usage de cet appareil muni de douille avec extension se révèle très utile sur aléseuse parce qu'il permet de centrer, percer et tarauder avec facilité en profitant d'un seul positionnement, sans avoir besoin d'exécuter le centrage sur aléseuse, puis le perçage et taraudage sur radiale.*

Husillo de roscado de cambio rápido con dispositivo guarda machos para roscado y taladrado.

Este es un husillo de soporte de herramienta que se extrae rápidamente con un dispositivo de protección de macho para pares preajustables y adecuado para brocas, mandrinadoras, tornos, etc. Este macho ofrece la ventaja de permitir cambio rápido de taladrado a roscado en diferentes diámetros sólo cambiando el casquillo sin necesidad de mayores ajustes ni comprobaciones.

Para cada tamaño de macho hay un casquillo preajustado y probado para un par adecuado para roscar cualquier material; sin embargo, obviamente este par no es suficiente para romper el macho en trabajos de roscado difíciles como roscado de agujeros fijos, mandrines con diámetros pequeños, materiales muy duros y muy resistentes o cuando el macho está excesivamente gastado.

Esta herramienta no solo cumple los requisitos de un husillo de cambio rápido convencional (capacidad – peso – dimensiones), sino que también tiene la ventaja de ser una excelente herramienta de roscado con par preajustable, el uso de este husillo es especialmente ventajoso cuando se deben preparar agujeros y roscas de diferentes tamaños sucesivamente en piezas duras que se mecanizan en brocas radiales y mandrinadoras, por ejemplo, matrices, bancadas de máquinas herramientas, carpintería, etc., sin riesgo de romper el macho en piezas caras y también es posible ahorrar mucho tiempo simplificando las operaciones de roscado.

Casquillo para roscado sin compensación Tipo N

Adaptado para el uso en máquinas de dimensiones medias, con avance manual suave, para seguir al macho en las operaciones de roscado.

Casquillo para roscado con recorrido de extracción Tipo AS

Para utilizar en tornos, mandrinadoras y máquinas pesadas para hacer pasos finos y también en materiales blandos. El uso del husillo con casquillo de extracción es especialmente ventajoso para mandrinadoras ya que permite un mandrinado y roscado fácil en la misma posición sin centrado y al proceder a la posición radial para mandrinado y roscado.



**CONO MORSE DIN 228 B**  
 MORSE CONE DIN 228 B  
 MORSEKEGEL DIN 228 B  
 CONE MORSE DIN 228 B  
 CONO MORSE DIN 228 B



CODICE CODE BESTELL NR CODE CODIGO	ATTACCO SHANK AUFNAHMEN ATTACHEMENT MANGO
11300/2	2
11300/3	3

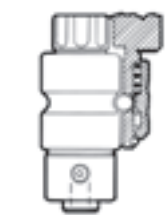

**BUSSOLE PER MASCHIARE TIPO "N"**  
 BUSHES FOR TAPPING TYPE "N"  
 SCHNELLWECHSELEINSÄTZE FÜR  
 GEWINDESCHNEIDEN TYP „N“  
 DOUILLES SANS COMPENSATION "TYPE "N"  
 CASQUILLOS PARA MACHO TIPO "N"

CODICE CODE BESTELL NR CODE CODIGO	Permaschl For Tap Für gewinde Pour taraud Para macho
11304/4	M4
11304/5	M5
11304/6	M6
11304/8	M8
11304/10	M10
11304/12	M12
11304/14	M14
11304/16	M16



**BUSSOLE PER MASCHIARE TIPO "AS"**  
 BUSHES FOR TAPPING TYPE "AS"  
 SCHNELLWECHSELEINSÄTZE FÜR GEWINDE  
 SCHNEIDEN TYP „AS“  
 DOUILLES DE TARAUDAGE TYPE "AS"  
 CASQUILLOS PARA MACHO TIPO "AS"

CODICE CODE BESTELL NR CODE CODIGO	Permaschl For Tap Für gewinde Pour taraud Para macho
11307/4	M4
11307/5	M5
11307/6	M6
11307/8	M8
11307/10	M10
11307/12	M12
11307/14	M14
11307/16	M16



**BUSSOLE PER FORARE, ATTACCO CONO MORSE**  
 BUSHES FOR DRILLING, MORSE CONE SHANK  
 SCHNELLWECHSELEINSÄTZE FÜR BOHREN,  
 MORSEKEGEL  
 DOUILLES DE PERÇAGE, ATTACHEMENT CONE MORSE  
 CASQUILLOS PARA BROCA, MANGO CONO MORSE

CODICE CODE BESTELL NR CODE CODIGO	Cono Morse Morse cone Morse Kegel Cone Morse Cono Morse
11305/1	1
11305/2	2
11305/3	3



**BUSSOLE PER FORATURA**  
 BUSHES FOR DRILL CHUCK  
 EINSÄTZE FÜR BOHREUTTER  
 DOUILLES POUR MANDRIN DE PERÇAGE  
 CASQUILLOS PARA PORTA BROCA

CODICE CODE BESTELL NR CODE CODIGO	ATTACCO SHANK AUFNAHMEN ATTACHEMENT MANGO
11305/BI2	BI2
11305/BI6	BI6



**BUSSOLE PER PINZE ER DIN6499**  
 BUSHES FOR ER COLLETS DIN 6499  
 EINSÄTZE FÜR SPANNZANGEN ER DIN 6499  
 DOUILLES POUR PINCES ER DIN 6499  
 CASQUILLOS PARA PINZAS ER DIN 6499

CODICE CODE BESTELL NR CODE CODIGO
11305/ER25

**CONO MORSE DIN 228 B**  
 MORSE CONE DIN 228 B  
 MORSEKEGEL DIN 228 B  
 CONE MORSE DIN 228 B  
 CONO MORSE DIN 228 B

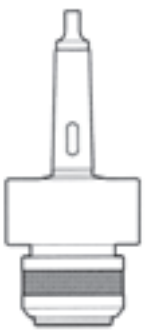

CODICE CODE BESTELL NR CODE CODIGO	ATTACCO SHANK AUFNAHMEN ATTACHEMENT MANGO
10540/3	3
10540/4	4

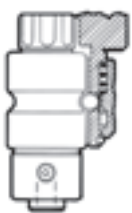

**BUSSOLE PER MASCHIARE TIPO "N"**  
 BUSHES FOR TAPPING TYPE "N"  
 SCHNELLWECHSELEINSÄTZE FÜR  
 GEWINDESCHNEIDEN TYP „N“  
 DOUILLES SANS COMPENSATION "TYPE "N"  
 CASQUILLOS PARA MACHO TIPO "N"

CODICE CODE BESTELL NR CODE CODIGO	Per maschi Für Tap Pour gwinde Pour taraud Para macho
10604/5	M5
10604/6	M6
10604/8	M8
10604/10	M10
10604/12	M12
10604/14	M14
10604/16	M16
10604/18	M18

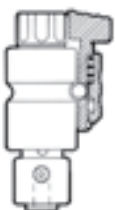

**BUSSOLE PER MASCHIARE TIPO "AS"**  
 BUSHES FOR TAPPING TYPE "AS"  
 SCHNELLWECHSELEINSÄTZE FÜR GEWINDE  
 SCHNEIDEN TYP „AS“  
 DOUILLES DE TARAUDAGE TYPE "AS"  
 CASQUILLOS PARA MACHO TIPO "AS"

CODICE CODE BESTELL NR CODE CODIGO	Per maschi Für Tap Pour gwinde Pour taraud Para macho
10607/5	M5
10607/6	M6
10607/8	M8
10607/10	M10
10607/12	M12
10607/14	M14
10607/16	M16
10607/18	M18

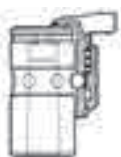

**BUSSOLE PER FORARE, ATTACCO CONO MORSE**  
 BUSHES FOR DRILLING, MORSE CONE SHANK  
 SCHNELLWECHSELEINSÄTZE FÜR BOHREN,  
 MORSEKEGEL  
 DOUILLES DE PERÇAGE, ATTACHEMENT CONE MORSE  
 CASQUILLOS PARA BROCA, MANGO CONO MORSE

CODICE CODE BESTELL NR CODE CODIGO	Cono Morse Morse cone Morse Kegel Cone Morse Cono Morse
10505/1	1
10505/2	2
10505/3	3
10505/4	4



**BUSSOLE PER FORATURA**  
 BUSHES FOR DRILL CHUCK  
 EINSÄTZE FÜR BOHRFLUTTER  
 DOUILLES POUR MANDRIN DE PERÇAGE  
 CASQUILLOS PARA PORTA BROCA

CODICE CODE BESTELL NR CODE CODIGO	ATTACCO SHANK AUFNAHMEN ATTACHEMENT MANGO
10505/B16	B16
10505/B18	B18

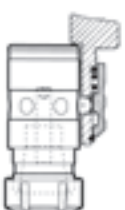

**BUSSOLE PER PINZARE DIN 6499**  
 BUSHES FOR ER COLLETS DIN 6499  
 EINSÄTZE FÜR SPANNZANGEN ER DIN 6499  
 DOUILLES POUR PINCES ER DIN 6499  
 CASQUILLOS PARA PINZAS ER DIN 6499

CODICE CODE BESTELL NR CODE CODIGO
10505/ER32



# SERIE 10600 M5-M27

**CONO MORSE DIN 228 B**  
 MORSE CONE DIN 228 B  
 MORSEKEGEL DIN 228 B  
 CONE MORSE DIN 228 B  
 CONO MORSE DIN 228 B



CODICE CODE BESTELL NR CODICE	ATTACCO SHANK AUFNAHMEN ATTACHEMENT MANGO
10600/4	4
10600/5	5

**ISO DIN 2080**



CODICE CODE BESTELL NR CODICE	ATTACCO SHANK AUFNAHMEN ATTACHEMENT MANGO
10600/40	40
10600/50	50

**ATTACCO CONO MORSE DIN 228-B**  
 DIN228-B-MORSE CONE SHANK  
 MORSEKEGELSCHAFT DIN 228-B  
 ATTACHEMENT CONE MORSE DIN 228-B  
 MANGO CONO MORSE DIN228-B



**ATTACCO CON FLANGIA**  
 SHANK WITH FLANGE  
 AUFNAHMEN MIT FLANSCH  
 ATTACHEMENT AVEC BRIDE  
 MANGO CON BRIDA



**ATTACCO CONO ISO**  
 ISO TAPER SHANK  
 ISO KONISCH SCHAF  
 ATTACHEMENT CONE ISO  
 MANGO CÓNICO ISO



CODICE CODE BESTELL NR CODICE	ATTACCO SHANK AUFNAHMEN ATTACHEMENT MANGO
10600/88	Ø 88

**BUSSOLE PER MASCHIARE TIPO "N"**  
 BUSHES FOR TAPPING TYPE "N"  
 SCHNELLEWECHSELEINSÄTZE FÜR  
 GEWINDESCHNEIDEN TYP "N"  
 DOUILLES SANS COMPENSATION "TYPE "N"  
 CASQUILLOS PARA MACHO TIPO "N"

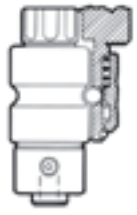

CODICE CODE BESTELL NR CODICE	Permaschi Für Tap Pour taraud Para macho
10604/5	M5
10604/6	M6
10604/8	M8
10604/10	M10
10604/12	M12
10604/14	M14
10604/16	M16
10604/18	M18
10604/20-22	M20-M22
10604/24-27	M24-M27

**BUSSOLE PER MASCHIARE TIPO "AS"**  
 BUSHES FOR TAPPING TYPE "AS"  
 SCHNELLEWECHSELEINSÄTZE FÜR GEWINDE  
 SCHNEIDEN TYP "AS"  
 DOUILLES DE TARAUDAGE TYPE "AS"



CODICE CODE BESTELL NR CODICE	Permaschi Für Tap Pour taraud Para macho
10607/5	M5
10607/6	M6
10607/8	M8
10607/10	M10
10607/12	M12
10607/14	M14
10607/16	M16
10607/18	M18
10607/20-22	M20-M22
10607/24-27	M24-M27

**BUSSOLE PER FORARE, ATTACCO CONO MORSE**  
 BUSHES FOR DRILLING, MORSE CONE SHANK  
 SCHNELLEWECHSELEINSÄTZE FÜR BOHREN, MORSEKEGEL  
 DOUILLES DE PERÇAGE, ATTACHEMENT CONE MORSE  
 CASQUILLOS PARA BROCA, MANGO CONO MORSE



CODICE CODE BESTELL NR CODICE	Cono Morse Morse cone Morse kegel Cone Morse
10505/1	1
10505/2	2
10505/3	3
10505/4	4

**BUSSOLE PER FORATURA**  
 BUSHES FOR DRILL CHUCK  
 EINSÄTZE FÜR BOHRFUTTER  
 DOUILLES POUR MANDRIN DE PERÇAGE  
 CASQUILLOS PARA PORTA BROCA



CODICE CODE BESTELL NR CODICE	ATTACCO SHANK AUFNAHMEN ATTACHEMENT MANGO
10505/B16	B16
10505/B18	B18

**BUSSOLE PER PINZE ER DIN6499**  
 BUSHES FOR ER COLLETS DIN 6499  
 EINSÄTZE FÜR SPANNZANGEN ER DIN 6499  
 DOUILLES POUR PINCES ER DIN 6499  
 CASQUILLOS PARA PINZAS ER DIN 6499

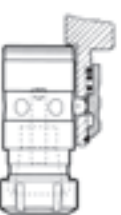

CODICE CODE BESTELL NR CODICE
10505/ER32

**CONO MORSE DIN 228 B**  
**MORSE CONE DIN 228 B**  
**MORSEKEGEL DIN 228 B**  
**CONE MORSE DIN 228 B**  
**CONO MORSE DIN 228 B**



CODICE CODE BESTELL NR CODE CODIGO	ATTACCO SHANK AUFNAHMEN ATTACHEMENT MANGO
10640/4	4
10640/5	5

**ISO DIN 2080**



CODICE CODE BESTELL NR CODE CODIGO	ATTACCO SHANK AUFNAHMEN ATTACHEMENT MANGO
10640/40	40
10640/50	50

**ATTACCO CONO MORSE DIN 228-B**  
**DIN228-B MORSE CONE SHANK**  
**MORSEKEGELSCHAFT DIN 228-B**  
**ATTACHEMENT CONE MORSE DIN 228-B**  
**MANGO CONO MORSE DIN228-B**



**ATTACCO CON FLANGIA**  
**SHANK WITH FLANGE**  
**AUFNAHMEN MIT FLANSCH**  
**ATTACHEMENT AVEC BRIDE**  
**MANGO CON BRIDA**

**ATTACCO CONO ISO**  
**ISO TAPER SHANK**  
**ISO KONISCH SCHAFT**  
**ATTACHEMENT CONE ISO**  
**MANGO CONICO ISO**

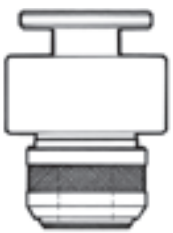

CODICE CODE BESTELL NR CODE CODIGO	ATTACCO SHANK AUFNAHMEN ATTACHEMENT MANGO
10640/88	Ø 88

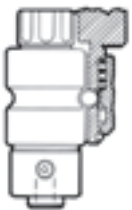

**BUSSOLE PER MASCHIARE TIPO "N"**  
**BUSHES FOR TAPPING TYPE "N"**  
**SCHNELLWECHSEL-EINSÄTZE FÜR**  
**GEWINDESCHNEIDEN TYP "N"**  
**DOUILLES SANS COMPENSATION "TYPE "N"**  
**CASQUILLOS PARA MACHO TIPO "N"**

CODICE CODE BESTELL NR CODE CODIGO	Per maschi For Tap Für gewinde Pour taraud Para macho
10604/5	M5
10604/6	M6
10604/8	M8
10604/10	M10
10604/12	M12
10604/14	M14
10604/16	M16
10604/18	M18
10604/20-22	M20-M22
10604/24-27	M24-M27
10644/30-33	M30-M33

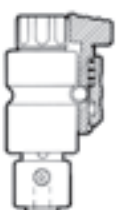

**BUSSOLE PER MASCHIARE TIPO "AS"**  
**BUSHES FOR TAPPING TYPE "AS"**  
**SCHNELLWECHSEL-EINSÄTZE FÜR GEWINDE**  
**SCHNEIDEN TYP "AS"**  
**DOUILLES DE TARAUDAGE TYPE "AS"**  
**CASQUILLOS PARA MACHO TIPO "AS"**

CODICE CODE BESTELL NR CODE CODIGO	Per maschi For Tap Für gewinde Pour taraud Para macho
10607/5	M5
10607/6	M6
10607/8	M8
10607/10	M10
10607/12	M12
10607/14	M14
10607/16	M16
10607/18	M18
10607/20-22	M20-M22
10607/24-27	M24-M27
10647/30-33	M30-M33



**BUSSOLE PER FORARE, ATTACCO CONO MORSE**  
**BUSHES FOR DRILLING, MORSE CONE SHANK**  
**SCHNELLWECHSEL-EINSÄTZE FÜR BOHREN,**  
**MORSEKEGEL**  
**DOUILLES DE PERÇAGE, ATTACHEMENT CONE MORSE**  
**CASQUILLOS PARA BROCA, MANGO CONO MORSE**

CODICE CODE BESTELL NR CODE CODIGO	Cono Morse Morse cone Cone Kegel Cone Morse Cono Morse
10505/1	1
10505/2	2
10505/3	3
10505/4	4



**BUSSOLE PER FORATURA**  
**BUSHES FOR DRILL CHUCK**  
**EINSÄTZE FÜR BOHRFUTTER**  
**DOUILLES POUR MANDRIN DE PERÇAGE**  
**CASQUILLOS PARA PORTA BROCA**

CODICE CODE BESTELL NR CODE CODIGO	ATTACCO SHANK AUFNAHMEN ATTACHEMENT MANGO
10505/16	B16
10505/18	B18

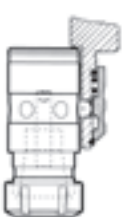

**BUSSOLE PER PINZE ER DIN6499**  
**BUSHES FOR ER COLLETS DIN 6499**  
**EINSÄTZE FÜR SPANNZANGEN ER DIN 6499**  
**DOUILLES POUR PINCES ER DIN 6499**  
**CASQUILLOS PARA PINZAS ER DIN 6499**

CODICE CODE BESTELL NR CODE CODIGO	ATTACCO SHANK AUFNAHMEN ATTACHEMENT MANGO
10505/ER32	





# SERIE 10800 M10-M42

CONO MORSE DIN 228 B  
MORSE CONE DIN 228 B  
MORSEKEGEL DIN 228 B  
CONE MORSE DIN 228 B  
CONO MORSE DIN 228 B



CODICE CODE BESTELL NR CODE CODIGO	ATTACCO SHANK AUFNAHMEN ATTACHEMENT MANGO
10800/5	5

ISO DIN 2080



CODICE CODE BESTELL NR CODE CODIGO	ATTACCO SHANK AUFNAHMEN ATTACHEMENT MANGO
10800/50	50

**ATTACCO CONO MORSE DIN 228-B**  
DIN228-B MORSE CONE SHANK  
MORSEKEGELSCHAFT DIN 228-B  
ATTACHEMENT CONE MORSE DIN 228-B  
MANGO CONO MORSE DIN228-B

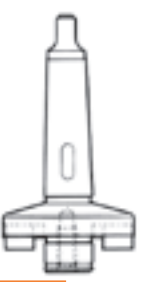

**ATTACCO CON FLANGIA**  
SHANK WITH FLANGE  
AUFNAHMEN MIT FLANSCH  
ATTACHEMENT AVEC BRIDE  
MANGO CON BRIDA

**ATTACCO CONO ISO**  
ISO TAPER SHANK  
ISO KONISCH SCHAFT  
ATTACHEMENT CONE ISO  
MANGO CONICO ISO



CODICE CODE BESTELL NR CODE CODIGO	ATTACCO SHANK AUFNAHMEN ATTACHEMENT MANGO
10800/128	Ø 128

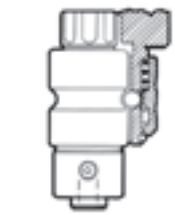
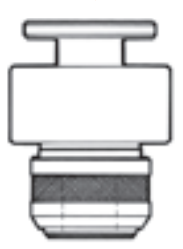

**BUSSOLE PER MASCHIARE TIPO "N"**  
BUSSES FOR TAPPING TYPE "N"  
SCHNELLWECHSELEINSÄTZE FÜR  
GEWINDESCHEIDEN TYP "N"  
DOUILLES SANS COMPENSATION "TYPE "N"  
CASQUILLOS PARA MACHO TIPO "N"

CODICE CODE BESTELL NR CODE CODIGO	Per maschl Für Tap Für gewinde Pour taraud Para macho
10804/10	M10
10804/12	M12
10804/14	M14
10804/16	M16
10804/18	M18
10804/20-22	M20-M22
10804/24-27	M24-M27
10804/30-33	M30-M33
10804/36-39	M36-M39
10804/42	M42

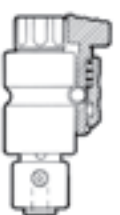

**BUSSOLE PER MASCHIARE TIPO "AS"**  
BUSSES FOR TAPPING TYPE "AS"  
SCHNELLWECHSELEINSÄTZE FÜR GEWINDE  
SCHEIDEN TYP "AS"  
DOUILLES DE TARAUDAGE TYPE "AS"  
CASQUILLOS PARA MACHO TIPO "AS"

CODICE CODE BESTELL NR CODE CODIGO	Per maschl Für Tap Für gewinde Pour taraud Para macho
10807/10	M10
10807/12	M12
10807/14	M14
10807/16	M16
10807/18	M18
10807/20-22	M20-M22
10807/24-27	M24-M27
10807/30-33	M30-M33
10807/36-39	M36-M39
10807/42	M42



**BUSSOLE PER FORARE, ATTACCO CONO MORSE**  
BUSSES FOR DRILLING, MORSE CONE SHANK  
SCHNELLWECHSELEINSÄTZE FÜR BOHREN,  
MORSEKEGEL  
DOUILLES DE PERÇAGE, ATTACHEMENT CONE MORSE  
CASQUILLOS PARA BROCA, MANGO CONO MORSE

CODICE CODE BESTELL NR CODE CODIGO	Cono Morse Morse cone Morse kegel Cone Morse Cono Morse
10805/2	2
10805/3	3
10805/4	4
10805/5	5



**BUSSOLE PER FORATURA**  
BUSSES FOR DRILL CHUCK  
EINSÄTZE FÜR BOHRFUTTER  
DOUILLES POUR MANDRIN DE PERÇAGE  
CASQUILLOS PARA PORTA BROCA

CODICE CODE BESTELL NR CODE CODIGO	ATTACCO SHANK AUFNAHMEN ATTACHEMENT MANGO
10805/B16	B16
10805/B18	B18

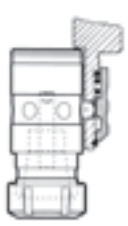

**BUSSOLE PER PINZE ER DIN6499**  
BUSSES FOR ER COLLETS DIN 6499  
EINSÄTZE FÜR SPANNZANGEN ER DIN 6499  
DOUILLES POUR PINCES ER DIN 6499  
CASQUILLOS PARA PINZAS ER DIN 6499

CODICE CODE BESTELL NR CODE CODIGO	ATTACCO SHANK AUFNAHMEN ATTACHEMENT MANGO
10805/ER40	

# SERIE 10900 M16-M64

## ATTACCO CONO MORSE DIN 228-B

DIN228-B MORSE CONE SHANK  
MORSEKEGELSCHAFT DIN 228-B  
ATTACHEMENT CONE MORSE DIN 228-B  
MANGO CONO MORSE DIN228-B



## ATTACCO CONO ISO

ISO TAPER SHANK  
ISO KONISCH SCHAFT  
ATTACHEMENT CONE ISO  
MANGO CONICO ISO



## ATTACCO CONO DIN 69871-A

DIN 69871-A TAPER SHANK  
DIN 69871-A KONISCH SCHAFT  
ATTACHEMENT CONE DIN 69871-A  
MANGO CONICO DIN 69871-A

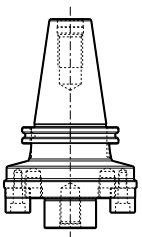

## ATTACCO CONO MAS 403 BT

MAS 403 BT TAPER SHANK  
MAS 403 BT KONISCH SCHAFT  
ATTACHEMENT CONE MAS 403 BT  
MANGO CONICO MAS 403 BT

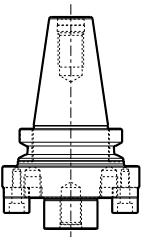

## ATTACCO CON FLANGIA

SHANK WITH FLANGE  
AUFNAHMEN MIT FLANSCH  
ATTACHEMENT AVEC BRIDE  
MANGO CON BRIDA

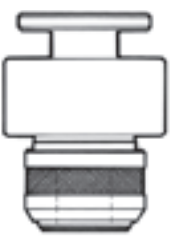

CODICE CODE BESTELL NR CODE CODIGO	ATTACCO SHANK AUFNAHMEN ATTACHEMENT MANGO
10900/128	Ø 128



BUSSOLE PER MASCHIARE TIPO "AS"  
BUSHES FOR TAPPING TYPE "AS"  
SCHNELLWECHSELEINSÄTZE FÜR TYP "AS"  
DOUILLES DE TARAUDAGE TYPE "AS"  
CASQUILLOS PARA MACHO TIPO "AS"

CODICE CODE BESTELL NR CODE CODIGO	Per maschi Für Tap Pour taraud Para macho
10907/16	M16
10907/18	M18
10907/20-22	M20-M22
10907/24-27	M24-M27
10907/30-33	M30-M33
10907/36-39	M36-M39
10907/42-45-48	M42-45-48
10907/52-56	M52-M56
10907/60-64	M60-M64

## BUSSOLE PER FORARE, ATTACCO CONO MORSE

BUSHES FOR DRILLING, MORSE CONE SHANK  
SCHNELLWECHSELEINSÄTZE FÜR BOHREN,  
MORSEKEGEL  
DOUILLES DE PERÇAGE, ATTACHEMENT CONE MORSE  
CASQUILLOS PARA BROCA, MANGO CONO MORSE

CODICE CODE BESTELL NR CODE CODIGO	Cono Morse Morse cone Morse kegel Cone Morse Cono Morse
10905/2	2
10905/3	3
10905/4	4
10905/5	5





# SERIE 10940 M16-M80

**ATTACCO CONO MORSE DIN 228-B**  
 DIN228-B MORSE CONE SHANK  
 MORSEKEGELSCHAFT DIN 228-B  
 ATTACHMENT CONE MORSE DIN 228-B  
 MANGO CONO MORSE DIN228-B



**ATTACCO CONO ISO**  
 ISO TAPER SHANK  
 ISO KONISCH SCHAFT  
 ATTACHEMENT CONE ISO  
 MANGO CONICO ISO



**ATTACCO CONO DIN 69871-A**  
 DIN 69871-A TAPER SHANK  
 DIN 69871-A KONISCH SCHAFT  
 ATTACHEMENT CONE DIN 69871-A  
 MANGO CONICO DIN 69871-A

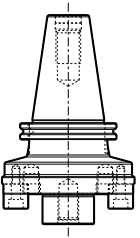

**ATTACCO CONO MAS 403 BT**  
 MAS 403 BT TAPER SHANK  
 MAS 403 BT KONISCH SCHAFT  
 ATTACHEMENT CONE MAS 403 BT  
 MANGO CONICO MAS 403 BT

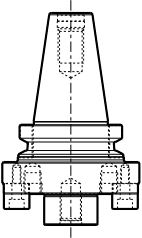

**ATTACCO CON FLANGIA**  
 SHANK WITH FLANGE  
 AUFNAHMEN MIT FLANSCHHE  
 ATTACHEMENT AVEC BRIDE  
 MANGO CON BRIDA



CODICE BESTELLE NR CODE CODIGO	ATTACCO AUFNAHMEN ATTACHEMENT MANGO
10940/128	Ø 128

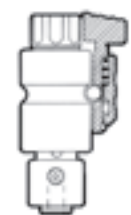

**BUSSOLE PER MASCHIARE TIPO "AS"**  
 BUSHES FOR TAPPING TYPE "AS"  
 SCHNELLWECHSELEINSÄTZE FÜR TYP "AS"  
 DOUILLES DE TARAUDAGE TYPE "AS"  
 CASQUILLOS PARA MACHO TIPO "AS"



**BUSSOLE PER FORARE, ATTACCO CONO MORSE**  
 BUSHES FOR DRILLING, MORSE CONE SHANK  
 SCHNELLWECHSELEINSÄTZE FÜR BOHREN,  
 MORSEKEGEL  
 DOUILLES DE PERÇAGE, ATTACHEMENT CONE MORSE  
 CASQUILLOS PARA BROCA, MANGO CONO MORSE

CODICE BESTELLE NR CODE CODIGO	Per maschi Für Tap Pour taraud Para macho
10907/16	M16
10907/18	M18
10907/20-22	M20 - M22
10907/24-27	M24 - M27
10907/30-33	M30 - M33
10907/36-39	M36 - M39
10907/42- 45-48	M42-45 -48
10907/52-56	M52 -M56
10907/60 -64	M60 -M64
10947/68-72	max M200 x p.3
10947/76-80	M76 - M80 (fino a M120) max M300 x p.3

CODICE BESTELLE NR CODE CODIGO	Cono Morse Morse cone Morse Kegel Cone Morse Cono Morse
10905/2	2
10905/3	3
10905/4	4
10905/5	5

# CONO MORSE DIN 228 B

MORSE CONE DIN 228 B  
MORSEKEGEL DIN 228 B  
CONE MORSE DIN 228 B  
CONO MORSE DIN 228 B

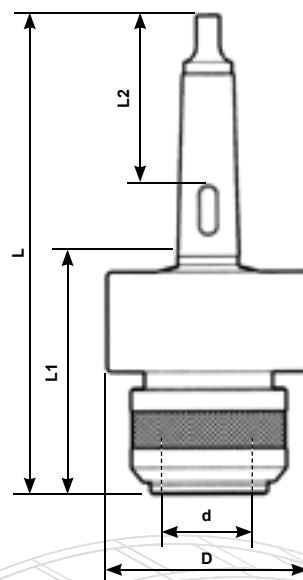

CODICE CODE BESTELL NR CODE CÓDIGO	ATTACCO SHANK AUFNAHMEN ATTACHEMENT MANGO	Dimensioni - Dimensions Abmessungen Dimensions - Dimensión					Capacità Maschiatura Tap capacity Bereich Capacité de Taroudage Capacidad macho	Bussola per maschiare Bushes for tapping Einsätze zu Gewinde Douille porte-taroud Casquillo para roscado	Cono morse in uscita Morse taper exit Morse Kegel Sortie Cone Morse Cono Morse de salida	Bussola per forare Bushes for drilling Einsätze zu Bohren Douille pour perçer Casquillo para broca	Peso Weight Gewicht Poids Peso Kg
		d	L	L1	L2	D					
11300/2 *	2	30	154	80		67	M4 - M16	11304/.. 11307/..	1-2	11305/..	1,200
11300/3 *	3	30	174	81		67	M4 - M16	11304/.. 11307/..	1-2-3	11305/..	1,350
10540/3	3	46	209	116		105	M5 - M18	10604/.. 10607/..	1-2-3	10505/..	3,550
10540/4	4	46	233	116	89	105	M5 - M18	10604/.. 10607/..	1-2-3-4	10505/..	3,800
10600/4	4	46	247	130	89	105	M5 - M27	10604/.. 10607/..	1-2-3-4	10505/..	4,600
10600/5	5	46	281	133	109	105	M5 - M27	10604/.. 10607/..	1-2-3-4	10505/..	5,500
10640/4	4	46	277	160	89	105	M5 - M33	10604/.. 10607/.. 10644/.. 10647/..	1-2-3-4	10505/..	5,000
10640/5	5	46	311	162	109	105	M5 - M33	10604/.. 10607/.. 10644/.. 10647/..	1-2-3-4	10505/..	5,900
10800/5	5	60	305	156	109	139	M10 - M42	10804/.. 10807/..	2-3-4-5	10805/..	9,100

\* A richiesta mandrino con capacità da M3 a M16.

\* Chuck with range M3-M16 on request.

\* Auf Anfrage Futter mit Bereich von M3 BIS M16.

\* Sur demande appareil avec capacité M3-M16.

\* Cono con capacidad de M3-M16 bajo pedido.

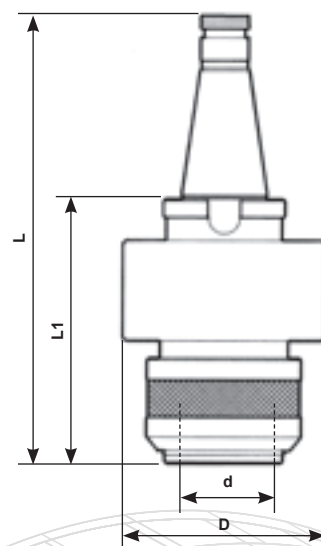

## ISO DIN 2080

CODICE CODE BESTELL NR CODE CÓDIGO	ATTACCO SHANK AUFNAHMEN ATTACHEMENT MANGO	Dimensioni- Dimensions Abmessungen Dimensionen- Dimensión				Capacità Maschiatura Tap capacity Bereich Capacité de Taraudage Capacidad macho	Bussola per maschiare Bushes for tapping Einsätze zu Gewinde Douille porte-tarud Casquillo para roscado	Cono morse in uscita Morse taper exit Morse Kegel Sortie Cone Morse Cono Morse de salida	Bussola per forare Bushes for drilling Einsätze zu Bohren Douille pour perçer Casquillo para broca	Peso Weight Gewicht Poids Peso Kg
		d	L	L1	D					
10600/40	40	46	232	139	105	M5 – M27	10604/.. 10607/..	1-2-3-4	10505/..	6,300
10600/50	50	46	265	138	105	M5 – M27	10604/.. 10607/..	1-2-3-4	10505/..	6,300
10640/40	40	46	262	169	105	M5 – M33	10604/.. 10607/..	1-2-3-4	10505/..	5,400
10640/50	50	46	295	168	105	M5 – M33	10604/.. 10607/..	1-2-3-4	10505/..	6,700
10800/50	50	60	285	158	139	M10 – M42	10804/.. 10807/..	2-3-4-5	10805/..	9,470

# ATTACCO CON FLANGIA

SHANK WITH FLANGE  
 AUFNAHMEN MIT FLANSCH  
 ATTACHEMENT AVEC BRIDE  
 MANGO CON BRIDA

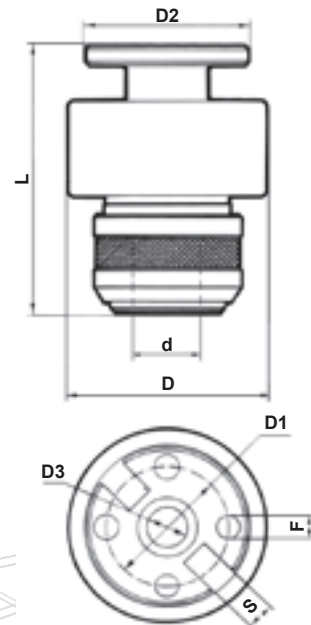

CODICE CODE BESTELL NR CODE CÓDIGO	ATTACCO SHANK AUFNAHMEN ATTACHEMENT MANGO	Dimensioni - Dimensions Abmessungen Dimensions - Dimensión								Capacità Maschiatura Tap capacity Bereich Capacité de Taraudage Capacidad macho	Bussola per maschiare Bushes for tapping Einsätze zu Gewinde Douille porte-taroud Casquillo para roscado	Cono morse in uscita Morse taper exit Morse Kegel Sortie Cone Morse Cono Morse de salida	Bussola per forare Bushes for drilling Einsätze zu Bohren Douille pour perçer Casquillo para broca	Peso Weight Poids Peso Kg
		d	L	D	D1	D2	D3	F	S					
10600/88	Ø 88	46	147	105	66,7	88,8	32	13	16	M5 – M27	10604/.. 10607/..	1-2-3-4	10505/..	4,350
10640/88	Ø 88	46	176	105	66,7	88,8	32	13	16	M5 – M33	10604/.. 10607/..	1-2-3-4	10505/..	7,000
10800/128	Ø 128	60	167	139	101,6	128,57	50	17	25,7	M10 – M42	10804/.. 10807/..	2-3-4-5	10805/..	8,540
10900/128	Ø 128	70	222	162	101,6	128,57	50	17	25,7	M16 – M64	10907/.. 10916/..	2-3-4-5	10905/..	18
10940/128	Ø 128	70	270	162	101,6	128,57	50	17	25,7	M16 – M120	10907/.. 10947/.. 10916/.. 10956/..	2-3-4-5	10905/..	24

# ATTACCO CONO MORSE DIN 228-B

DIN228-B MORSE CONE SHANK  
 MORSEKEGELSCHAFT DIN 228-B  
 ATTACHEMENT CONE MORSE DIN 228-B  
 MANGO CONO MORSE DIN228-B

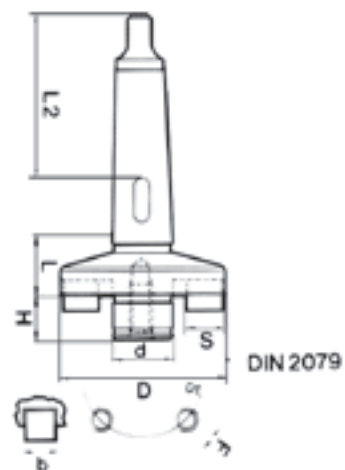

CODICE CODE BESTELL NR CODE CÓDIGO	ATTACCO SHANK AUFNAHMEN ATTACHEMENT MANGO	Dimensioni - Dimensions Abmessungen Dimensions - Dimensión								
		L	D	d	DI	H	b	F	S	L2
14.32.04	CM4	34	88,8	32	66,7	23	16	M12	19	89
14.32.05	CM5	37	88,8	32	66,7	23	16	M12	19	109
24.50.05	CM5	38	128,57	50	101,6	26	25,7	M16	24	109

# ATTACCO CONO ISO

ISO TAPER SHANK  
ISO KONISCH SCHAFT  
ATTACHEMENT CONE ISO  
MANGO CÓNICO ISO

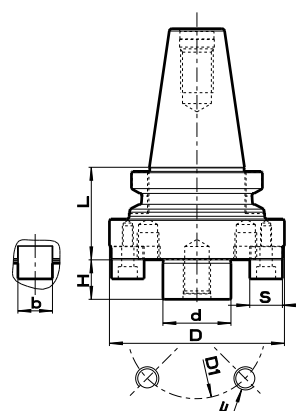

CODICE CODE BESTELL NR CODE CÓDIGO	ATTACCO SHANK AUFNAHMEN ATTACHEMENT MANGO	Dimensioni - Dimensions Abmessungen Dimensions - Dimensión							
		L	D	d	DI	H	b	F	S
16.32.40	ISO 40 DIN 2080	38	88,8	32	66,7	23	16	M12	19
16.32.50	ISO 50 DIN 2080	41	88,8	32	66,7	23	16	M12	19
26.50.50	ISO 50 DIN 2080	38	128,57	50	101,6	26	25,7	M16	24
16.32.50A	ISO 50 DIN 69871	68	88,8	32	66,7	26	16	M12	19
26.50.50A	ISO 50 DIN 69871	72	128,57	50	101,6	29	25,7	M16	24
26.50.50BT	ISO 50 DIN 7388-2	68	128,57	50	101,6	26	25,7	M16	24

**A richiesta si forniscono attacchi non in tabella.**

*On request special attachments are provided.*

Anfrage von Spezial-Schäften auch möglich, diese sind nicht in der Tabelle enthalten.

*Sur demande attachement différents de ceux prévus au catalogue.*

Accesorios especiales bajo pedido