



MASCHIATORI A CAMBIO RAPIDO SERIE 21080

TAPPING CHUCK SERIE 21080

GEWINDESCHNEIDFUTTER SERIE 21080

APPAREILS À TARAUDER SERIE 21080

MANDRINO DE ROSCADO SERIE 21080

Senza compensazione assiale

Without axial compensation

Ohne Längenausgleich

Sans compensation axiale

Sin compensacion axial





**MASCHIATORI SERIE 21080 SENZA COMPENSAZIONE ASSIALE
CON PASSAGGIO LUBRIFICANTE (VERSIONI CONO ISO)**

MASCHIATORI SERIE 21080

Adatti per macchine CNC predisposte per la "maschiatura rigida".

**SERIES 21080 TAPPING CHUCK WITHOUT AXIAL COMPENSATION
WITH COOLANT FLOW (ISO TAPER)**

SERIES 21080 TAPPING CHUCK MACHINING CENTRES

Suitable for use on CNC machines with rigid tapping cycles.

**GEWINDESCHNEID-SCHNELLWECHSELFUTTER OHNE
LÄNGENAUSGLEICH SERIE 21080**

GEWINDESCHNEID-SCHNELLWECHSELFUTTER SERIE 21080

Für Maschinen mit starr gewindeschneid programm.

**APPAREILS À TARAUDER SERIE 21080 SANS
COMPENSATION AXIALE AVEC PASSAGE LUBRIFIANT (CONE ISO)**

APPAREILS A TARAUDER SERIE 21080

Recommandés pour des machines CNC destinées au «taraudage synchronisé».





MASCHIATORE ATTACCO CONO MORSE DIN 228-B SENZA COMPENSAZIONE ASSIALE

Principalmente usati su macchine con avanzamento manuale e con patrona

TAPPING CHUCK WITHOUT AXIAL COMPENSATION MORSE CONE DIN 228-B

Mainly used on hand feed machines and with pattern

GEWINDESCHNEIDFUTTER OHNE LÄNGENAUSGLEICH MIT MORSEKEGEL DIN 228-B

Verwendung auf handgeführten Bearbeitungsmaschinen oder

Maschinen mit Gewindefunktio

APPAREIL À TARAUDER AVEC CONE MORSE DIN 228-B SANS COMPENSATION AXIALE

Principalement utilisé sur les machines conventionnelles et avec patronne

MANDRINO DE ROSCADO SIN COMPENSACIÓN AXIAL CONO MORSE DIN 228-B

Usado principalmente en máquinas de alimentación manual y con patrón

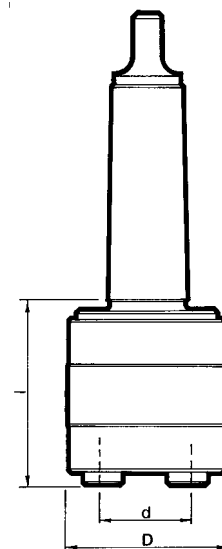

CODICE CODE BESTELL NR CODE CÓDIGO	ATTACCO SHANK AUFNAHMEN ATTACHEMENT MANGO	d	D	l	Capacità Maschiatura Tap capacity Bereich Capacité de taroudage Capacidad macho	Bussola Bush Einsatz Douille Casquillo
21280/1	1	13	23	35	M2-M10	13/..
21280/2	2	13	23	37	M2-M10	13/..
21480/2	2	19	33	45	M3-M12	19/..
21480/3	3	19	33	45	M3-M12	19/..
21680/2	2	31	50	61	M6-M20	31/..
21680/3	3	31	50	61	M6-M20	31/..
21680/4	4	31	50	61	M6-M20	31/..
21880/4	4	48	72	92	M14-M33	48/..



MASCHIATORE ATTACCO CONO MORSE DIN 228-A SENZA COMPENSAZIONE ASSIALE

Principalmente usati su macchine con avanzamento manuale e patrona.

TAPPING CHUCK WITHOUT AXIAL COMPENSATION WITH MORSE CONE DIN 228-A

Mainly used on hand feed machines and with pattern.

GEWINDESCHNEIDFUTTER OHNE LÄNGENAUSGLEICH MIT MORSEKEGEL DIN 228-A

Verwendung auf handgeführten Bearbeitungsmaschinen oder

Maschinen mit Gewindeschneidfunktion.

APPAREIL À TARAUDER AVEC CONE MORSE DIN 228-A SANS COMPENSATION AXIALE

Principalement utilisé sur les machines conventionnelles et avec patronne

MANDRINO DE ROSCADO SIN COMPENSACIÓN AXIAL CONO MORSE DIN 228-A

Usado principalmente en máquinas de alimentación manual y con patrón

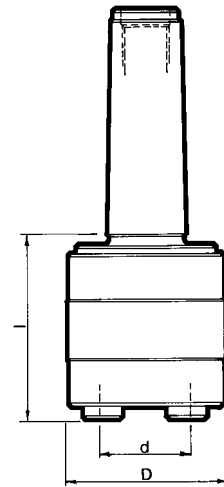

CODICE CODE BESTELL NR CODE CÓDIGO	ATTACCO SHANK AUFNAHMEN ATTACHEMENT MANGO	d	D	l	Capacità Maschiatura Tap capacity Bereich Capacité de taraudage Capacidad macho	Bussola Bush Einsatz Douille Casquillo
21480/2F	2	19	33	45	M3-M12	19/..
21480/3F	3	19	33	45	M3-M12	19/..
21680/2F	2	31	50	61	M6-M20	31/..
21680/3F	3	31	50	61	M6-M20	31/..
21680/4F	4	31	50	61	M6-M20	31/..





MASCHIATORE ATTACCO CODOLO CILINDRICO DIN 1835 B+E SENZA COMPENSAZIONE E CON PASSAGGIO LUBRIFICANTE

Principalmente usati su macchine CNC predisposte per maschiatura rigida.

CYLINDRICAL SHANK TAPPING CHUCKS DIN 1835 B+E WITHOUT AXIAL COMPENSATION WITH COOLANT FLOW

Mainly used on CNC machines fitted out for rigid tapping.

GEWINDESCHNEIDFUTTER OHNE LÄNGENAUSGLEICH MIT ZYLINDERSCHAFT DIN 1835 B+E UND ZENTRALER KÜHLMITTELZUFUHR

Verwendung auf CNC Maschinen mit Gewindeschneidfunktion.

APPAREIL À TARAUDER AVEC ATTACHEMENT CYLINDRIQUE DIN 1835 B+E SANS COMPENSATION AXIALE ET AVEC PASSAGE DU LUBRIFIANT

Utilisé sur machines CNC prévues pour le taraudage rigide

MANDRINO DE ROSCADO DE MANGO CILÍNDRICO DIN 1835 B+E SIN COMPENSACIÓN AXIAL Y CON REFRIGERACIÓN INTERIOR

Usado principalmente en máquinas CNC equipadas para roscado rígido

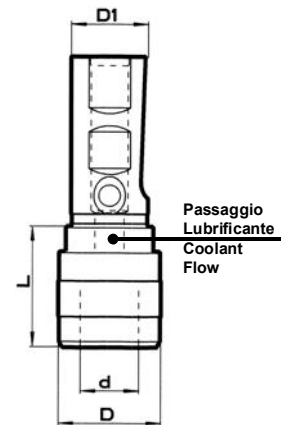

CODICE CODE BESTELL NR CODE CÓDIGO	ATTACCO SHANK AUFNAHMEN ATTACHEMENT MANGO D1	d	D	L	Capacità Maschiatura Tap capacity Bereich Capacité de taraudage Capacidad macho	Bussola Bush Einsatz Douille Casquillo
21480/D20	20	19	33	40	M3-M12	19/..
21480/D25	25	19	33	40	M3-M12	19/..
21480/D32	32	19	33	40	M3-M12	19/..
21480/D40	40	19	33	40	M3-M12	19/..
21680/D20	20	31	50	63	M6-M20	31/..
21680/D25	25	31	50	63	M6-M20	31/..
21680/D32	32	31	50	63	M6-M20	31/..
21680/D40	40	31	50	63	M6-M20	31/..
21880/D40	40	48	72	87	M14-M33	48/..



MASCHIATORE ATTACCO CONICO DIN 238-A SENZA COMPENSAZIONE ASSIALE

Principalmente usati su macchine con avanzamento manuale e con patrona.

TAPPING CHUCK WITHOUT AXIAL COMPENSATION WITH MORSE CONE DIN 238-A

Mainly used on hand feed machines and with pattern.

GEWINDESCHNEIDFUTTER OHNE LÄNGENAUSGLEICH MIT MORSEKEGEL DIN 238-A

Verwendung auf handgeführten Bearbeitungsmaschinen oder Maschinen mit Gewindeschneidfunktion.

APPAREIL À TARAUDER AVEC CONE MORSE DIN 238-A SANS COMPENSATION AXIALE

Principalement utilisé sur les machines conventionnelles et avec patronne.

MANDRINO DE ROSCADO SIN COMPENSACIÓN AXIAL CONO MORSE DIN 238-A

Usado principalmente en máquinas de alimentación manual y con patrón.

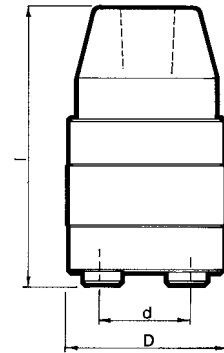

CODICE CODE BESTELL NR CODE CÓDIGO	ATTACCO SHANK AUFNAHMEN ATTACHEMENT MANGO	d	D	l	Capacità Maschiatura Tap capacity Bereich Capacité de taraudage Capacidad macho	Bussola Bush Einsatz Douille Casquillo
21280/B10	B10	13	23	50	M2-M10	13/..
21280/B12	B12	13	23	54	M2-M10	13/..
21480/B12	B12	19	33	59	M3-M12	19/..
21480/B16	B16	19	33	65	M3-M12	19/..
21480/B18	B18	19	33	72	M3-M12	19/..
21680/B12	B12	31	50	74,5	M6-M20	31/..
21680/B16	B16	31	50	80	M6-M20	31/..
21680/B18	B18	31	50	88	M6-M20	31/..



MASCHIATORE ATTACCO CONO ISO DIN 69871-A SENZA COMPENSAZIONE ASSIALE CON PASSAGGIO LUBRIFICANTE

Principalmente usati su macchine CNC predisposte per la maschiatura rigida.

TAPPING CHUCK WITHOUT AXIAL COMPENSATION WITH COOLANT FLOW DIN 69871-A

Mainly used on CNC machines fitted out for rigid tapping.

GEWINDESCHNEIDFUTTER OHNE LÄNGENAUSGLEICH MIT STEILKEGEL DIN 69871-A UND ZENTRALER KÜHLMITTELZUFUHR

Verwendung auf CNC Maschinen mit Gewindefunktion.

APPAREIL À TARAUDER AVEC CONE ISO DIN 69871-A SANS COMPENSATION AXIALE ET AVEC PASSAGE DU LUBRIFIANT

Utilisé sur les machines CNC prévues pour le taraudage rigide

MANDRINO DE ROSCADO CÓNICO ISO DIN 69871-A SIN COMPENSACIÓN AXIAL Y CON REFRIGERACIÓN INTERIOR

Usado principalmente en máquinas CNC equipadas para roscado rígido.

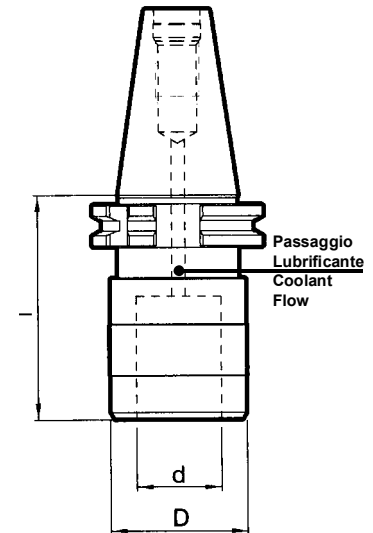
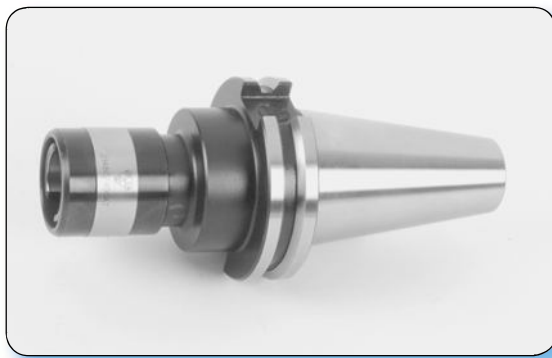

CODICE CODE BESTELL NR CODE CÓDIGO	ATTACCO SHANK AUFNAHMEN ATTACHEMENT MANGO	d	D	l	Capacità Maschiatura Tap capacity Bereich Capacité de taraudage Capacidad macho	Bussola Bush Einsatz Douille Casquillo
21480/30A	30	19	33	59	M3-M12	19/..
21480/40A	40	19	33	59	M3-M12	19/..
21480/50A	50	19	33	75	M3-M12	19/..
21680/30A	30	31	50	80	M6-M20	31/..
21680/40A	40	31	50	86	M6-M20	31/..
21680/50A	50	31	50	98	M6-M20	31/..
21880/40A	40	48	72	122	M14-M33	48/..
21880/50A	50	48	72	122	M14-M33	48/..

A richiesta anche in versione ISO DIN 69871-AD+B con afflusso del lubrificante dai fori laterali.

On request also in ISO DIN 69871-AD+B with coolant flow through the side hole.

Auf Anfrage mit schaft nach ISO DIN 69871-AD+B mit seitlicher Kühlmittelzufuhr Lieferbar.

Sur demande version ISO DIN 69871-AD+B avec le passage du lubrifiant par les trous latéraux.

Bajo pedido también en ISO DIN 69871-AD+B con refrigeración a través de agujero lateral.





MASCHIATORE ATTACCO CONO MAS 403 BT SENZA COMPENSAZIONE ASSIALE E CON PASSAGGIO LUBRIFICANTE

Principalmente usati su macchine CNC predisposte per maschiatura rigida.

MAS 403 BT TAPPING CHUCK WITHOUT AXIAL COMPENSATION AND WITH COOLANT FLOW

Mainly used on CNC machines fitted out for rigid tapping.

GEWINDESCHNEIDFUTTER OHNE LÄNGENAUSGLEICH MIT STEILKEGEL MAS 403 BT UND ZENTRALER KÜHLMITTELZUFUHR

Verwendung auf CNC Maschinen mit Gewindegewindfunktion.

APPAREIL À TARAUDER AVEC CONE MAS 403 BT SANS COMPENSATION AXIALE ET AVEC PASSAGE DU LUBRIFIANT

Utilisé sur les machines CNC prévues pour le taraudage rigide

MANDRINO DE ROSCADO CÓNICO MAS 403 BT

SIN COMPENSACIÓN AXIAL Y CON REFRIGERACIÓN INTERIOR

Usado principalmente en máquinas CNC equipadas para roscado rígido

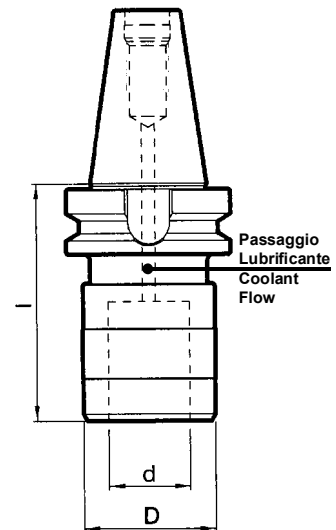
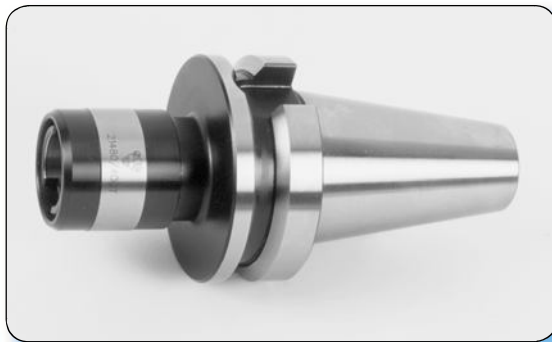

CODICE CODE BESTELL NR CODE CÓDIGO	ATTACCO SHANK AUFNAHMEN ATTACHEMENT MANGO	d	D	l	Capacità Maschiatura Tap capacity Bereich Capacité de taraudage Capacidad macho	Bussola Bush Einsatz Douille Casquillo
21480/30BT	30	19	33	62	M3-M12	19/..
21480/40BT	40	19	33	67	M3-M12	19/..
21480/50BT	50	19	33	78	M3-M12	19/..
21680/30BT	30	31	50	85	M6-M20	31/..
21680/40BT	40	31	50	90	M6-M20	31/..
21680/50BT	50	31	50	101	M6-M20	31/..
21880/40BT	40	48	72	117	M14-M33	48/..
21880/50BT	50	48	72	125	M14-M33	48/..

A richiesta anche in versione MAS BT-B con afflusso del lubrificante dai fori laterali.
 On request also in MAS BT-B with coolant flow through the side hole.
 Auf Anfrage mit schaft nach MAS BT-B mit seitlicher kühlmittelezufuhr Lieferbar.
 Sur demande version MAS BT-B avec le passage du lubrifiant par les trous latéraux.
 Bajo pedido también en MAS BT-B con refrigeración a través de agujero lateral





MASCHIATORE ATTACCO CONO ISO DIN 2080 SENZA COMPENSAZIONE ASSIALE E CON PASSAGGIO LUBRIFICANTE

Principalmente usati su macchine CNC predisposte per maschiatura rigida.

ISO DIN 2080 RIGID TAPPING CHUCK WITH COOLANT FLOW , WITHOUT AXIAL COMPENSATION

Mainly used on CNC machines fitted out for rigid tapping.

GEWINDESCHNEIDFUTTER OHNE LÄNGENAUSGLEICH MIT STEILKEGEL DIN 2080 UND ZENTRALER KÜHLMITTELZUFUHR

Verwendung auf CNC Maschinen mit Gewindeschneidfunktion.

APPAREIL À TARAUDER AVEC CONE ISO DIN 2080 SANS COMPENSATION AXIALE ET AVEC PASSAGE DU LUBRIFIANT

Utilisé sur les machines CNC prévues pour le taraudage rigide

MANDRINO DE ROSCADO CÓNICO ISO DIN 2080

SIN COMPENSACIÓN AXIAL Y CON REFRIGERACIÓN INTERIOR

Usado principalmente en máquinas CNC equipadas para roscado rígido.

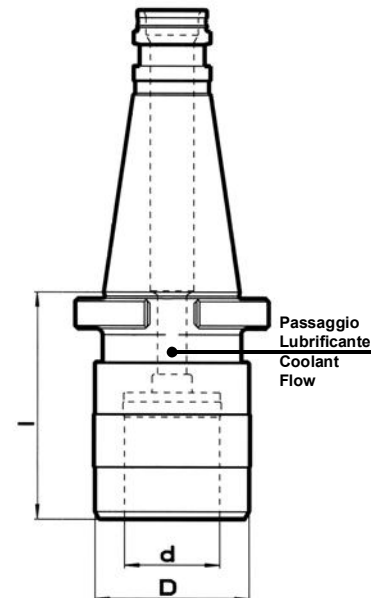

CODICE CODE BESTELL NR CODE CÓDIGO	ATTACCO SHANK AUFNAHMEN ATTACHEMENT MANGO	d	D	l	Capacità Maschiatura Tap capacity Bereich Capacité de taraudage Capacidad macho	Bussola Bush Einsatz Douille Casquillo
21480/30	30	19	33	50	M3-M12	19/..
21480/40	40	19	33	52	M3-M12	19/..
21480/50	50	19	33	55	M3-M12	19/..
21680/30	30	31	50	73	M6-M20	31/..
21680/40	40	31	50	74	M6-M20	31/..
21680/50	50	31	50	78	M6-M20	31/..

