

# SISTEMA DI BLOCCAGGIO MANUALE HSK DIN 69893 TIPO C

MANUAL LOCKING SYSTEM FOR HSK SHANKS  
DIN 69893 TYPE C

MANUELLES BLOCKIERUNGSSYSTEM FÜR  
HSK TYP C NACH DIN 69893

SYSTEME DE BLOCAGE MANUEL HSK TYPE C  
DIN 69893

SISTEMA DE BLOQUEO MANUAL PARA  
MANGOS HSK TIPO C DIN 69893

**Il sistema di bloccaggio manuale per attacchi HSK tipo C è utilizzato prevalentemente su macchine utensili a teste multiple, per l'aggancio di sistemi modulari per centri di lavoro e torni CNC.**

*The manual locking system for HSK shanks type C is mainly used on multi-heads machine tools for the locking of modular systems for machining centres and CNC lathes.*

Das manuelles Blockierungssystem für HSK typ C Aufnahmen wird hauptsächlich verwendet auf Bearbeitungszentren mit verschiedene Spindel, fuer das Ankuppeln von Modular Systeme auf CNC Maschinen.

*Le système de blocage manuel pour les attachements HSK type C est utilisé surtout sur machines a tetes multiple, pour l'accrochage de systemes modulaires sur centres d'usinage et tours CNC.*

El sistema de bloqueo manual para mangos HSK tipo C se utiliza principalmente en máquinas herramientas con cabezales múltiples para el bloqueo de sistemas modulares para centros de mecanizado y tornos CNC.



# FLANGIA TIPO F01 CON GIUNTO DI SERRAGGIO

F01 FLANGE WITH CLAMPING JOINT  
FLANSCH TYP F01 MIT BEFESTIGUNGSFUGE  
FLASQUE TYPE F01 AVEC SYSTEME DE SERRAGE  
F01 BRIDA CON JUNTA DE BLOQUEO



CODICE CODE BESTELL NR CODE CÓDIGO	ATTACCO SHANK AUFNAHMEN ATTACHEMENT MANGO
HX32C-00-F01	HSK32
HX40C-00-F01	HSK40
HX50C-00-F01	HSK50
HX63C-00-F01	HSK63

# FLANGIA TIPO F01

F01 FLANGE  
FLANSCH TYP 01  
FLASQUE TYPE F01  
F01 BRIDA



Sede per viti brugola M  
Seat for screws  
Sitz für schrauben

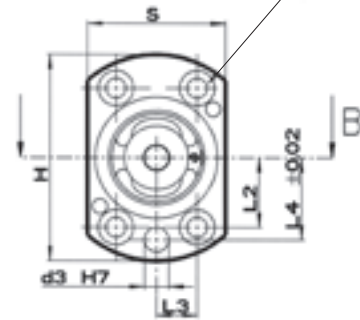

CODICE CODE BESTELL NR CODE CÓDIGO	ATTACCO SHANK AUFNAHMEN ATTACHEMENT MANGO	Dimensioni - Dimensions - Abmessungen Dimensions - Dimensión										
		D	d	L	L1	L2	L3	d3	L4	H	S	M
HF32C-00-F01	HSK32C	32	32	37	10	19,2	10,5	6	22	55	36	5
HF40C-00-F01	HSK40C	40	40	45	12	23	13,5	8	27	68	45	6
HF50C-00-F01	HSK50C	50	50	57	15	30	16	10	35	85	56	8
HF63C-00-F01	HSK63C	63	63	70	15	37	20,5	12	44	106	70	8

# GIUNTI DI SERRAGGIO HSK TIPO C

## CLAMPING JOINT HSK FORM C BEFESTIGUNGSFUGE FÜR HSK FORM C SYSTEME DE SERRAGE HSK FORME C JUNTA DE BLOQUEO FORMA C

### Per torni a CNC e centri di lavoro plurimandrino

*For CNC lathes and machining centers with multihead*  
Für CNC Drehmaschinen und Mehrspindel Bearbeitungszenter  
*Pour tours et Centres d'usinage CNC multi broches*  
Para tornos CNC y centros de mecanizado plurimandrino

### Fresature e torniture in sgrossatura e finitura con alte sollecitazioni assiali

*Milling and turning in roughing and finishing with high axial loads*  
Für fräsen und drehen auf schrappen und schlichten hohen Axialkräfte  
*Fraisage et tournage d'ébauche et finition avec charge axiale importante*  
Fresados y torneados en desbaste y acabado con elevados esfuerzos axial

### Alimentazione centrale del lubrificante

*Central coolant through*  
Zentraler Kühlmittelzuführ  
*Arrosage central*  
Canal central de refrigerante

### Espulsore per lo sbloccaggio

*Ejector for release*  
Ausstoß-Vorrichtung zum Entblocken  
*Ejecteur de démontage*  
Expulsor para desbloqueo

### Per HSK 32/40/50/63/100

*For HSK 32/40/50/63/100*  
Für HSK 32/40/50/63/100  
*Pour HSK 32/40/50/63/100*  
Para HSK 32/40/50/63/100

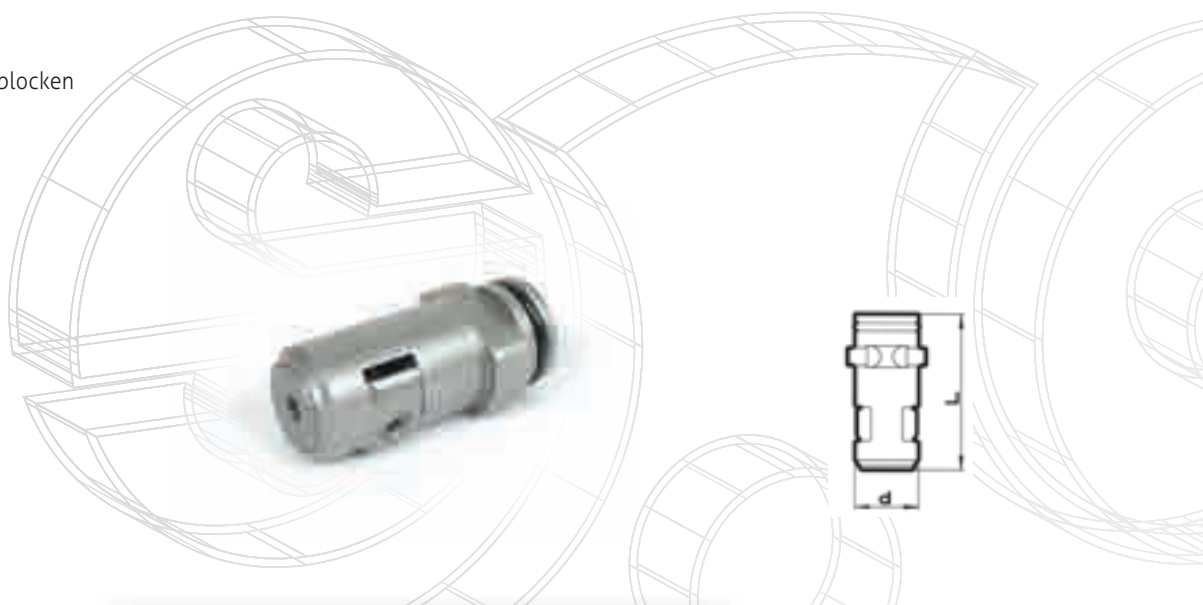

CODICE CODE BESTELL NR CODE CÓDIGO	ATTACCO SHANK AUFNAHMEN ATTACHEMENT MANGO	Dimensioni Dimensions Abmessungen Dimensions Dimensión	
		d	L
HN32C-00	HSK32	16,8	42
HN40C-00	HSK40	20,8	50,5
HN50C-00	HSK50	25,7	62,6
HN63C-00	HSK63	33,6	74,6
HN100C-00	HSK100	52	118