



SISTEMA DI BLOCCAGGIO MANUALE HSK DIN 69893 TIPO C **MANUAL LOCKING SYSTEM FOR HSK SHANKS DIN 69893** **TYPE C**

MANUELLES BLOCKIERUNGSSYSTEM FÜR HSK TYP C NACH **DIN 69893**

SYSTEME DE BLOCAGE MANUEL HSK TYPE C DIN 69893

SISTEMA DE BLOQUEO MANUAL PARA MANGOS HSK TIPO C **DIN 69893**

Il sistema di bloccaggio manuale per attacchi HSK tipo C è utilizzato prevalentemente su macchine utensili a teste multiple, per l'aggancio di sistemi modulari per centri di lavoro e torni CNC.

The manual locking system for HSK shanks type C is mainly used on multi-heads machine tools for the locking of modular systems for machining centres and CNC lathes.

Das manuelles Blockierungssystem für HSK typ C Aufnahmen wird hauptsächlich verwendet auf Bearbeitungszentren mit verschiedene Spindel, fuer das Ankuppeln von Modular Systeme auf CNC Maschinen.

Le système de blocage manuel pour les attachements HSK type C est utilisé surtout sur machines a tetes multiple, pour l'accrochage de systemes modulaires sur centres d'usinage et tours CNC.

El sistema de bloqueo manual para mangos HSK tipo C se utiliza principalmente en máquinas herramientas con cabezales múltiples para el bloqueo de sistemas modulares para centros de mecanizado y tornos CNC.





FLANGIA TIPO F01 CON GIUNTO DI SERRAGGIO
F01 FLANGE WITH CLAMPING JOINT
FLANSCH TYP F01 MIT BEFESTIGUNGSFUGE
FLASQUE TYPE F01 AVEC SYSTEME DE SERRAGE
F01 BRIDA CON JUNTA DE BLOQUEO

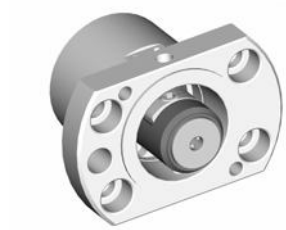
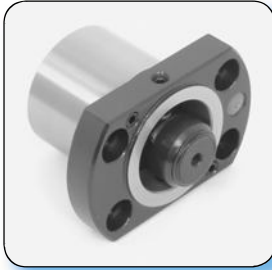

CODICE CODE BESTELL NR CODE CÓDIGO	ATTACCO SHANK AUFNAHMEN ATTACHEMENT MANGO
HX32C-00-F01	HSK32
HX40C-00-F01	HSK40
HX50C-00-F01	HSK50
HX63C-00-F01	HSK63





FLANGIA TIPO F01
F01 FLANGE
FLANSCH TYP 01
FLASQUE TYPE F01
F01 BRIDA

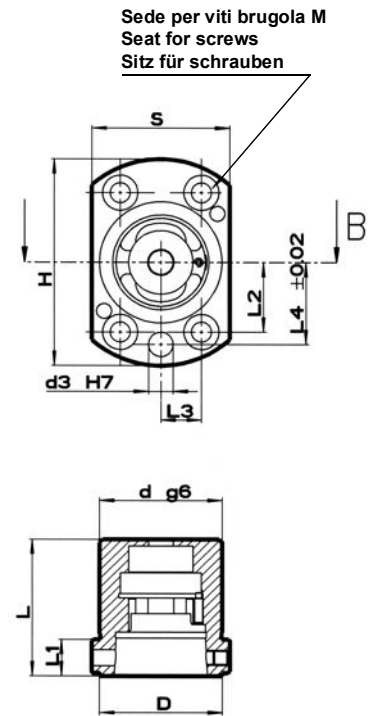

CODICE CODE BESTELL NR CODE CÓDIGO	ATTACCO SHANK AUFNAHMEN ATTACHEMENT MANGO	Dimensioni - Dimensions - Abmessungen Dimensions - Dimensión									
		D	d	L	L1	L2	L3	d3	L4	H	S
HF32C-00-F01	HSK32C	32	32	37	10	19,2	10,5	6	22	55	36
HF40C-00-F01	HSK40C	40	40	45	12	23	13,5	8	27	68	45
HF50C-00-F01	HSK50C	50	50	57	15	30	16	10	35	85	56
HF63C-00-F01	HSK63C	63	63	70	15	37	20,5	12	44	106	70





GIUNTI DI SERRAGGIO HSK TIPO C
CLAMPING JOINT HSK FORM C
BEFESTIGUNGSFUGE FÜR HSK FORM C
SYSTEME DE SERRAGE HSK FORME C
JUNTA DE BLOQUEO FORMA C

Per torni a CNC e centri di lavoro plurimandrino
For CNC-lathes and machining centers with multihead
Für CNC Drehmaschinen und Mehrspindel Bearbeitungszenter
Pour tours et Centres d'usinage CNC multi broches
Para tornos CNC y centros de mecanizado plurimandrino

Fresature e torniture in sgrossatura e finitura con alte sollecitazioni assiali
Milling and turning in roughing and finishing with high axial loads
Für fräsen und drehen auf schrappen und schlichten mit hohe axialkräften
Fraisage et tournage d'ébauche et finition avec charge axiale importante
Fresados y torneados en desbaste y acabado con elevados esfuerzos axial

Alimentazione centrale del lubrificante
Central coolant through
Zentraler Kuhlmitelzuführ
Arrosage central
Canal central de refrigerante

Espulsore per lo sbloccaggio
Ejector for release
Ausstoß-Vorrichtung zum lösen
Ejecteur de démontage
Expulsor para desbloqueo

Per HSK 32/40/50/63/100
For HSK 32/40/50/63/100
Für HSK 32/40/50/63/100
Pour HSK 32/40/50/63/100
Para HSK 32/40/50/63/100

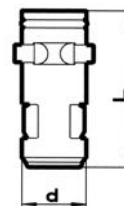

CODICE CODE BESTELL NR CODE CÓDIGO	ATTACCO SHANK AUFNAHMEN ATTACHEMENT MANGO	Dimensioni Dimensions Abmessungen Dimensions Dimensión	
		d	L
HN32C-00	HSK32	16,8	42
HN40C-00	HSK40	20,8	50,5
HN50C-00	HSK50	25,7	62,6
HN63C-00	HSK63	33,6	74,6

